

Caratteristiche - Features - Merkmale - Caractéristiques - Características  
 Χαρακτηριστικά - Características - Kenmerken - Özellikler - Funktionen - Vlastnosti - Vlastnosti



<b>Manuale d'uso, manutenzione e parti di ricambio</b>	<b>Parte 2</b>
<b>Manual for use, maintenance and spare parts</b>	<b>Part 2</b>
<b>Bedienungs- und Wartungshandbuch sowie Ersatzteilliste</b>	<b>Teil 2</b>
<b>Mode d'emploi, de maintenance et pièces de rechange</b>	<b>Partie 2</b>
<b>Manual de uso, mantenimiento y recambios</b>	<b>Part 2</b>
<b>Εγχειρίδιο χρήσης, συντήρησης και ανταλλακτικών</b>	<b>Μέρος 2</b>
<b>Manual de uso, manutenção e peças sobresselentes</b>	<b>Parte 2</b>
<b>Handleiding voor gebruik, onderhoud en wisselstukken</b>	<b>Deel 2</b>
<b>Kullanım, bakım ve yedek parça kılavuzu</b>	<b>Kisim 2</b>
<b>Användar-, underhålls- och reservdelshandbok</b>	<b>Del 2</b>
<b>Návod k používání a údržbě a náhradní díly</b>	<b>Část 2</b>
<b>Návod na obsluhu, údržbu a náhradné diely</b>	<b>Časť 2</b>



**1016.50**

cod. 1858600



**Warning: Please read the instructions and warnings for this tool carefully before use. Failure to do so could lead to serious injury.**

Dati tecnici Technical data Technische Daten Tekniska data	Caractéristiques techniques Datos técnicos Τεχνικά χαρακτηριστικά Technické údaje	Dados técnicos Technische gegevens Teknik veriler Technické údaje		
<b>Misure impiegabili</b> Lengths Verwendbare Nagellänge Dimensioner som kan användas	Dimensions utiles Medidas de longitud Μήκος Αναλωσίμου Příпустné rozměry	Medidas utilizáveis Toepasbare afmetingen Boy Použitelné rozmery	<b>mm</b> <b>inch</b>	<b>20÷50</b> <b>3/4"÷2"</b>
<b>Capacità caricatore n° punti</b> Magazine capacity Magazinkapazität: Nägel Magasinkapacitet: Antal punkter	Capacité chargeur n° de points Capacidad cargador n° puntos Δυνατότητα γεμιστέρα Kapacita zásobníku p. sponek	Capacidade carregador n° pontos Capaciteit magazijn in aantal spijkers Dergi kapasitesi Kapacita zásobníka p. spôn		<b>145</b>
<b>Pressione d'esercizio</b> Operating pressure Betriebsdruck Drifttryck	Pression d'exercice Presión de servicio Πίεση λειτουργίας Pracovní tlak	Pressão de serviço Werkdruk Çalışma basıncı Prevádzkový tlak	<b>bar</b> <b>psi</b>	<b>5÷7,5</b> <b>70÷105</b>
<b>Consumo aria</b> Air consumption Luftverbrauch Luftförbrukning	Consommation d'air Consumo aire Κατανάλωση αέρα Spotřeba vzduchu	Consumo ar Luchtverbruik Hava tüketimi Spotřeba vzduchu	<b>lt/colpo</b> <b>ft<sup>3</sup>/cycle</b>	<b>1,22</b> <b>0,70280</b>
<b>Peso</b> Weight Gewicht Vikt	Poids Peso Βάρος Hmotnost	Peso Gewicht Ağırlık Hmotnost	<b>kg</b> <b>lbs</b>	<b>2,24</b> <b>4,94</b>
<b>Dimensioni</b> Dimensions Abmessungen Dimensioner (AxBxH)	Dimensions Dimensiones Διαστάσεις Rozměry	Dimensões Afmetingen Boyutlar Rozmery	<b>mm</b> <b>inch</b>	<b>352x91x263</b> <b>13-7/8"x3-19/32"x10-3/8"</b> (LxWxH)
<b>EN 12549 :2009 EN ISO 4871 :2009</b>				
<b>Pressione sonora in pos. operatore</b> Sound pressure in operator's position Schalldruck am Arbeitsplatz Ljudtryck på operatörsplatsen	Pression sonore poste Opérateur Presión sonora en la pos. del operador Ηχητική πίεση στη θέση του χειριστή Akustický tlak v místě obsluhy	Pressão sonora na posição Operador Geluidsdruk op de werkplaats Οπερατόρ pozisyonunda ses basıncı Akustický tlak v mieste obsluhy	<b>dB(A)</b>	<b>92</b> (K= 4 dB)
<b>EN 12549 :2009 EN ISO 3746 :2011 EN ISO 4871 :2009</b>				
<b>Potenza sonora emessa</b> Sound power emitted Emitierte Schalleistung Avgiven ljudeffekt	Puissance sonore émise Potencia sonora emitida Εκπεμπόμενη ηχητική ισχύς Emitovaný akustický tlak	Potência sonora emitida Geëmitteerd geluidsvermogen Çıkan ses gücü (ses desibeli) Výstupný akustický výkon	<b>dB(A)</b>	<b>99</b> (K= 4 dB)
<b>CEN ISO/TS 8662-11 :2006 EN ISO 5349-2 :2004 EN 12096 :1999</b>				
<b>Emissione vibratoria sull'impugnatura</b> Vibratory emissions on handle Vibrationsemission am Griff Vibrationsemission på handtaget	Émission vibratoire sur la prise en main Emisión de vibraciones en la empuñadura Εκπεμπόμενες δονήσεις στη λαβή Emise vibrací na rukojet	Emissão vibratória na empunhadura Trillingsemissie op de handgreep Tutamak üzerinde vibrasyon emisyonları Emisie vibrácií na rukoväti	<b>m/s<sup>2</sup></b>	<b>4,16</b> (K= 2 m/s <sup>2</sup> )

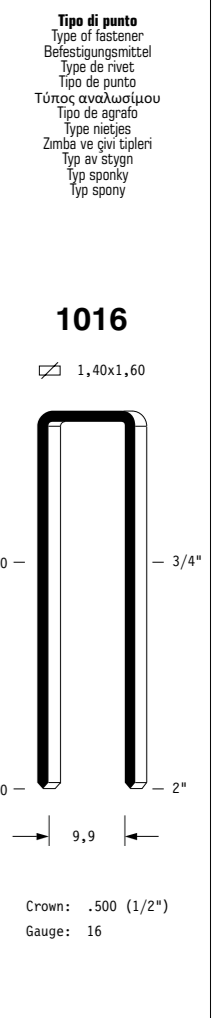



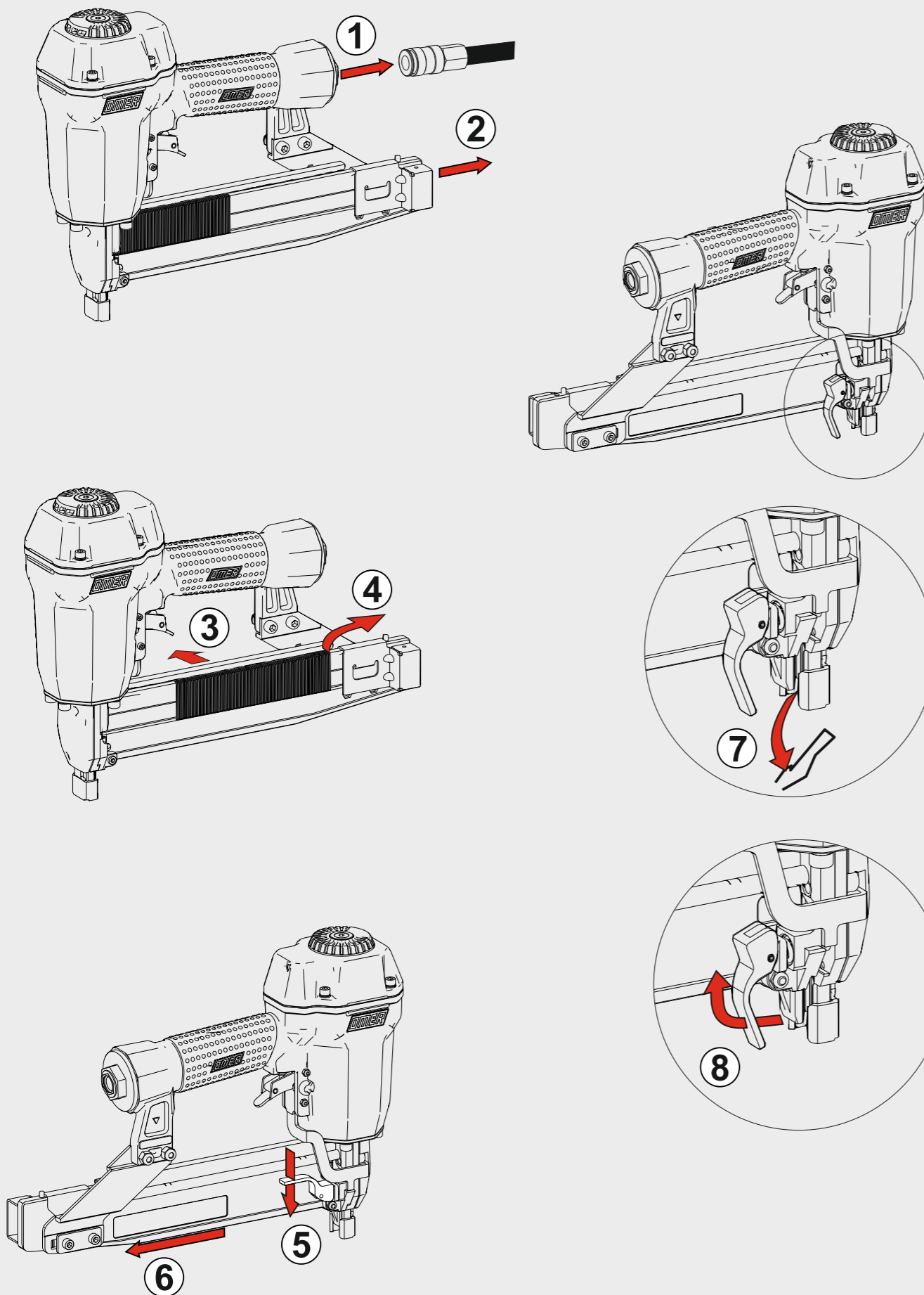

Cod.	Descrizione	Description
00.11	O-Ring	O-Ring
00.13	O-Ring	O-Ring
00.14	O-Ring	O-Ring
00.15.2	O-Ring	O-Ring
00.21	O-Ring	O-Ring
00.48	O-Ring	O-Ring
00.54	O-Ring	O-Ring
01.46	O-Ring	O-Ring
01.53	O-Ring	O-Ring
01.57	O-Ring	O-Ring
01.75	O-Ring	O-Ring
02.45	O-Ring	O-Ring
02.48	O-Ring	O-Ring
03.00	Dado	Nut
03.04.5	Vite	Screw
03.31	Vite	Screw
04.00	Dado	Nut
04.26	Vite	Screw
05.00	Dado	Nut
05.20	Vite	Screw
05.25	Vite	Screw
06.00.2	Dado	Nut
06.10.5	Vite	Screw
06.14	Vite	Screw
06.20	Vite	Screw
06.25.2	Vite	Screw
07.25	Chiave esagonale	Hex. bar wrench
07.30	Chiave esagonale	Hex. bar wrench
07.40	Chiave esagonale	Hex. bar wrench
07.50	Chiave esagonale	Hex. bar wrench
09.15	Rondella	Washer
09.16	Rondella	Washer
09.21	Anello elastico	Elastic ring
10.55	O-Ring	O-Ring
13.14.2	Spina	Pin
17.27	Tappo	Inlet cap
21.85	Corpo	Body
22.85	Testa	Head
25.81	Deflettore	Deflector
26.85	Cilindro	Cylinder
27.85	Anello cilindro	Cylinder ring
28.81	Guarnizione testa	Head gasket
30.85	Pistone	Piston
32.85	Ammortizzatore	Bumper
40.85	Valvola completa	Valve ass'y
43.12.7	Rondella	Washer
44.84	Guarnizione cilindro	Cylinder gasket
44.85	Ammortizzatore	Bumper
45.85	Distanziale	Spacer
50.85	Pulsante completo	Trigger valve ass'y
51.85	Boccola pulsante	Trigger valve housing
53.85	Pistone servovalvola	Valve piston
54.83	Pulsante	Trigger valve
55.85	Raccordo pulsante	Bush
64.82	Carter	Hold down
64.85	Carter sicura	Safety Guard
71.86	Reggicaricatore	Support
73.81	Perno	Pin
73.82	Perno	Pin
75.85	Sicura	Safety
77.81	Guida sicura	Safety guide
80.85	Leva	Lever
81.83	Grilletto comando	Trigger
83.80	Rondella	Washer
83.81	Piastrina	Plate
83.82	Piastrina	Plate
86.80	Boccola	Bush
90.83	Molla	Spring
91.21	Molla	Spring
91.84	Molla	Spring
91.85	Molla	Spring
91.86	Molla	Spring
92.80	Molla	Spring
93.81	Molla	Spring
23.80.75	Battente	Driver
52.80.74	Caricatore	Magazine
62.80.74	Nasello	Nose
72.80.74	Spingipunto	Pusher
81.80.00	Flangia	Flange
92.80.75	Testina	Nose plate
D01	Bocchetta olio	Oiler
D02	Occhiali protettivi	Protective goggles

Guarnizioni - O-Rings - Dichtungen - Joints - Junta - Δακτύλιος στεγανοποίησης - Vedantes - O-ringen - Contaljar - O-ringar - Těsnění - Tesnenia

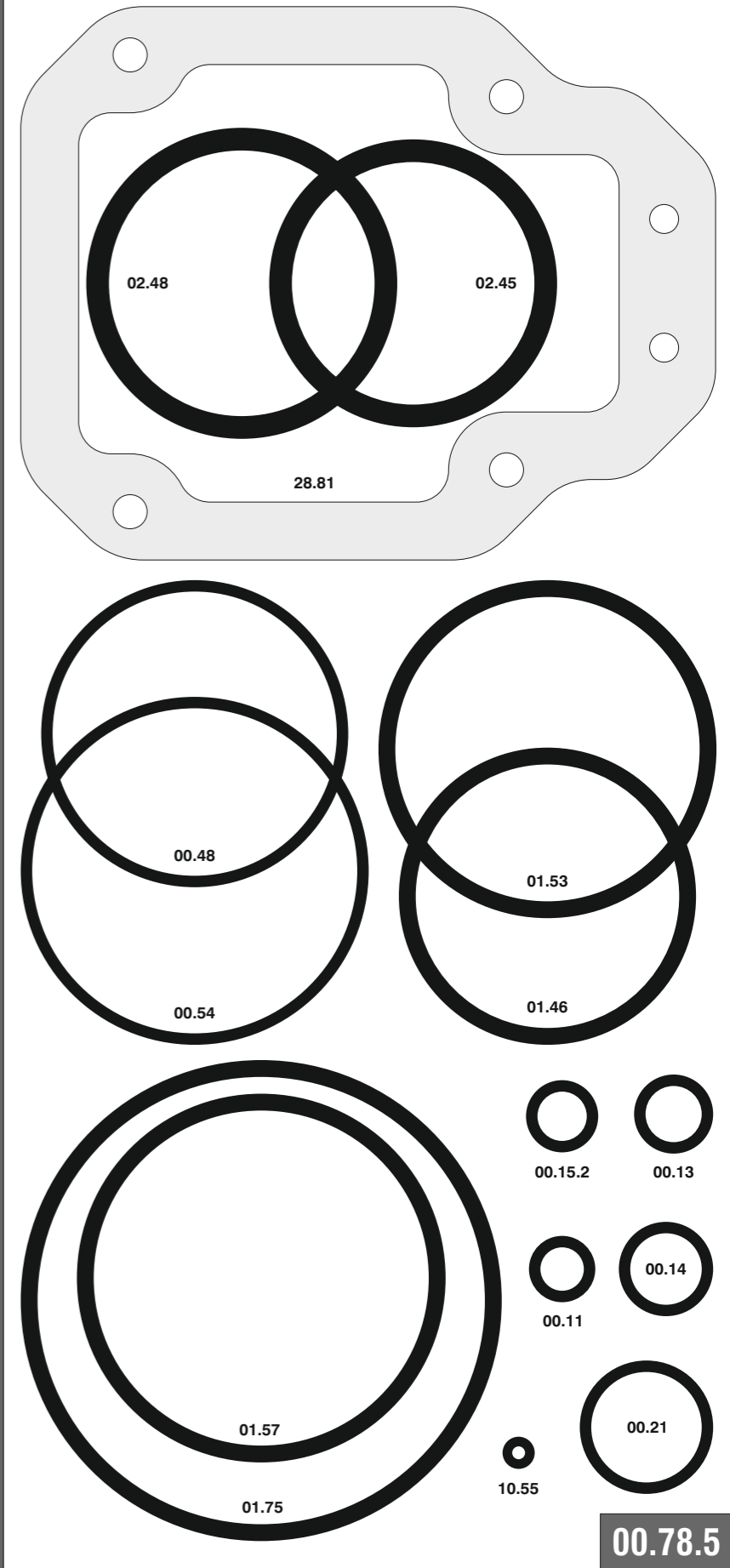

1016.50

cod. 1858600

Indice di modifica Upgrade number **5**

**Azionamento a contatto**  
Contact actuation

81.83

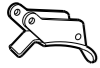

Di serie / Standard

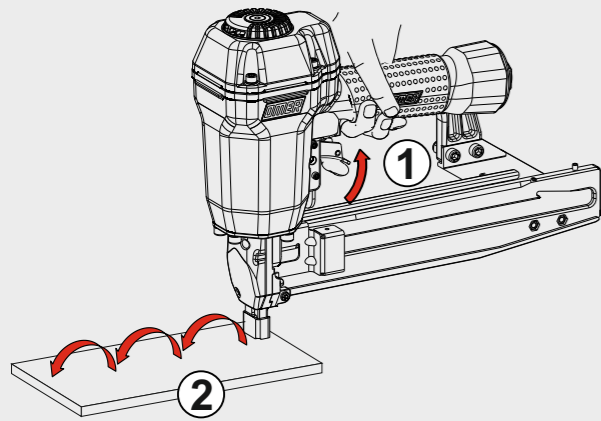

Oppure - Or

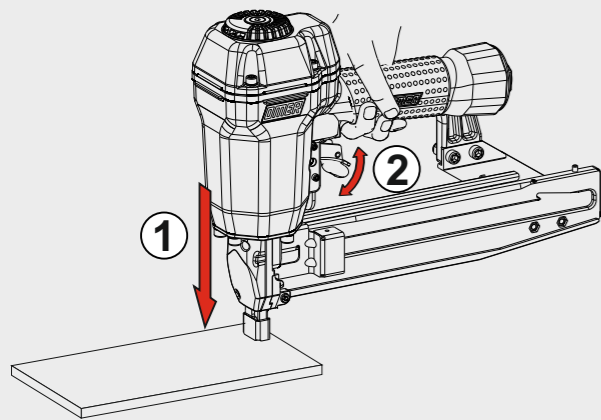

**Azionamento sequenziale singolo**  
Single sequential actuation

81.83.1



A richiesta / On request

